

PowerBoss®
The Power of Clean

**User Manual
Nautilus E
Battery Operated
Cylindrical
Rider Scrubber\Sweeper**

Model: SM45CQP



**PowerBoss®, Minuteman International, Inc.
A Member of the Hako Group**

#988768UM Rev. B 06/20

PREFACE

Thank you for your purchase of the new industry standard for scrubber/sweepers. PowerBoss® takes great pride in offering the most dependable, reliable and best value in industrial power scrubbers and sweepers. We set the standard.

Our Customer Service Department would like to hear from you. If you see any errors, omissions or something that needs clarification in this User Manual, please let us know. We are working hard towards continually improving our processes--to benefit you, our valued customer.

Please copy the form below, fill out and comment on how you found our manual.

Thank you!

The PowerBoss Team

Name: _____

Title: _____

Company Name: _____

Address: _____

Country: _____

Type of equipment or model number: _____

Comments: _____

Please return to:

Customer Service Manager

PowerBoss®, Minuteman International, Inc.

14N845 U.S. Route 20

Pingree Grove, Illinois 60140 USA

Phone: (800) 323-9420

Email: tech@powerboss.com

This is the User Manual for the PowerBoss® Nautilus E Rider Scrubber/Sweeper.

This manual covers all Standard Natuilus E machine variations beginning April 2020.

We believe this machine will provide excellent service for many years.

However, the best results will be obtained if:

- The machine is operated with reasonable care.
- The machine is maintained regularly per the maintenance schedule provided in this User Manual.
- The machine is maintained with PowerBoss® supplied or equivalent parts.

All right side and left side references to the machine are determined by facing the direction of forward travel. Some hardware considered to be common or locally available has been omitted from the parts section to make this manual clear. Be sure to use equivalent hardware when replacement becomes necessary.

The Model and Serial Number of your machine is shown on the I.D. name plate. This information is needed when contacting Technical Support or when ordering parts. The I.D. plate is mounted on the left side wall of the operator seating area.

Example I.D. Plate:

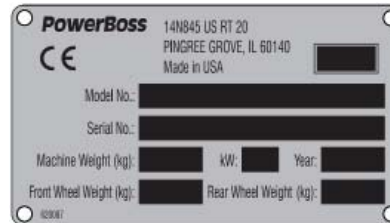

Parts may be ordered by phone, fax or e-mail from your local PowerBoss® parts and service center. Before ordering parts or supplies, be sure to have your machine Model Number and Serial Number handy. For your convenience Fill out the Machine Data block for future reference.

MACHINE DATA Fill out at installation	
Model Number:	_____
Serial Number:	_____
Sales Rep.:	_____ Date of Install: _____

All information contained in this catalog is current at the time of printing. Minuteman International, Inc. reserves the right to make changes at any time without notice.

PowerBoss®, Minuteman International, Inc., Copyright 2014-2015, Printed in USA

TECHNICAL SPECIFICATIONS

Model: Nautilus E Battery Operated Cylindrical Rider Scrubber/Sweeper

Model No.: SM45CQP

SPECIFICATIONS	
Propel speed forward (transport)	5.5 mph
Propel speed forward (scrubbing)	4 mph
Propel speed reverse	3 mph
Propel motor	3.0 hp AC
Gradeability Transport (empty for trailering)	12 degrees
With counter weight option	12 degrees
Transport at gross weight	7 degrees
With counter weight option	8.5 degrees
Working (scrubbing)	5 degrees
With counter weight option	6 degrees
Ground clearance	2.75 in
Tire front (1) non marking	13.8 x 5.8 in
Rear tires (2)	15 x 5 in
Weight empty	3400 lbs
With 510AH batteries	7870 lbs
With 930AH batteries	5550 lbs

SPECIFICATIONS	
Gross vehicle weight	7000 lbs
Minimum aisle u-turn	94.75 in (9 ft aisle)
Battery (est. continuous runtime) –	
Economy mode:	
Up to 3.5 hours	36V, 750 AH
Up to 5.5 hours	36V, 840 AH
Full Shift w/Opportunity Charg	LITHIUM
Machine Dimensions	
Length	85.5 in
Width	55 in
w/optional side scrub brush	61.75
Height top of recovery tank	58.12
w/overhead guard	78 in

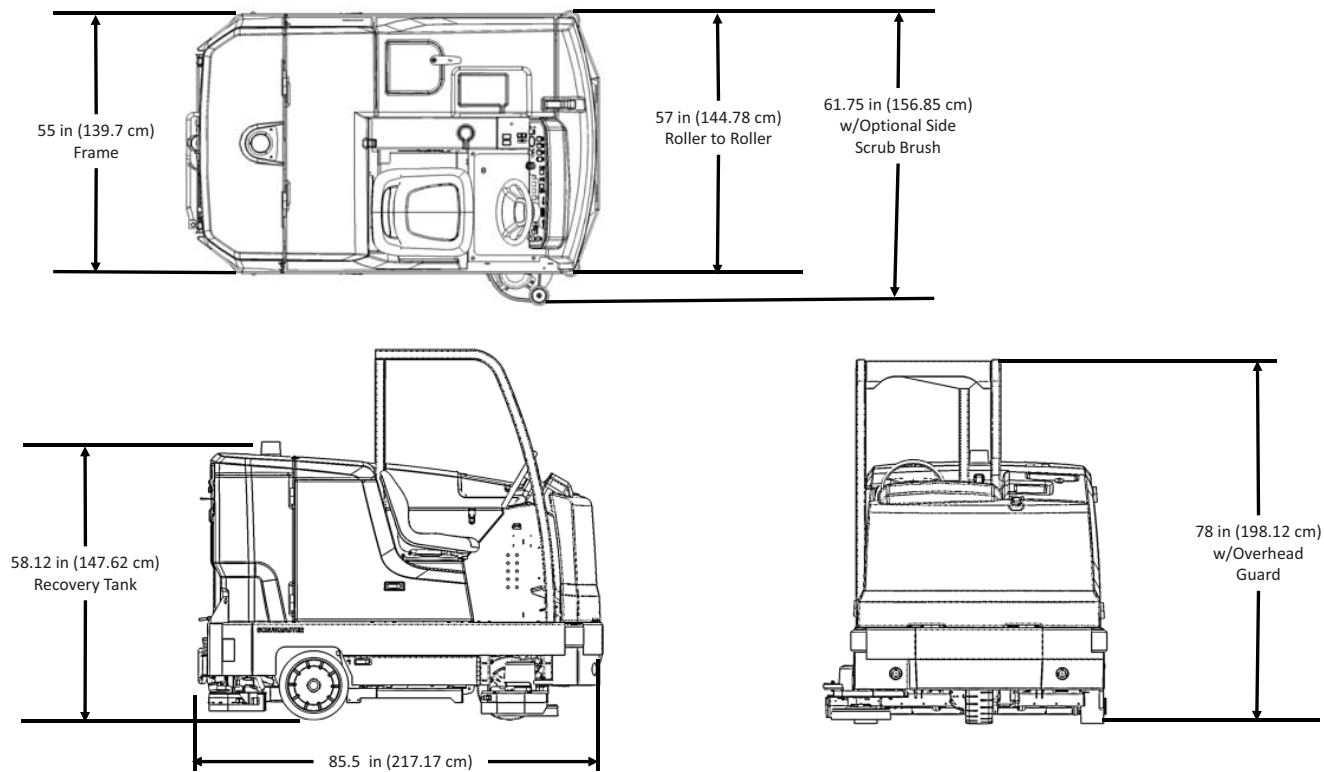

TABLE OF CONTENTS

PREFACE	2
TECHNICAL SPECIFICATIONS	6
FEATURES	12
AIR-MOVING SYSTEM	12
ERGONOMICS SYSTEM	12
CHASSIS SYSTEM	12
ENVIRONMENTAL FRIENDLY FEATURES	12
SAFER WORK ENVIRONMENT	12
SAFETY INFORMATION	12
IMPORTANT SAFETY INSTRUCTIONS	12
FOR SAFETY DURING OPERATION	13
SAFETY WHEN SERVICING OR MAINTAINING	13
SAFETY SYMBOLS	14
SAFETY DECALS	15
BASIC POWERBOSS® SAFETY	17
MACHINE OPERATION	20
OPERATING CONTROLS AND INDICATORS	20
KEY SWITCH	20

LIGHT SWITCH	20
HORN BUTTON	20
CIRCUIT BREAKER	20
HOUR METER	20
INDICATOR LIGHTS	20
RECOVERY TANK FULL INDICATOR	20
SOLUTION TANK EMPTY INDICATOR	22
BATTERY DISCHARGE INDICATOR	22
DIRECTIONAL CONTROL SWITCH	22
BRAKE / PARKING BRAKE	22
SEAT ADJUSTMENT	22
CONTROL PEDAL	22

INSTRUMENT PANEL CONTROL SWITCHES ... 23

GREEN "ONE-TOUCH" SWITCH	24
SQUEEGEE SWITCH	24
SCRUB BRUSH SWITCH	24
SIDE SCRUB BRUSH SWITCH - OPTION	24
MAIN BRUSH SCRUB PRESSURE SWITCH	26
SOLUTION CONTROL KNOB	26

BASIC SCRUBBING/FILLING/EMPTYING INFORMATION 27

CHOOSING THE CORRECT TYPE OF BRUSH. 27
FILLING THE SOLUTION TANK. 28
FILLING THE SOLUTION TANK. 29
NORMAL SCRUBBING. 30
DOUBLE SCRUBBING 32
STOP SCRUBBING. 33
WATER PICK UP MODE (SQUEEGEE ONLY) 34
STOP WATER PICK UP 35
DRAINING/CLEANING THE RECOVERY TANK 36
RAISING THE BUMPER 38
EMPTYING/CLEANING THE DEBRIS HOPPER 39
DRAINING THE SOLUTION TANK 40

OPERATING PROCEDURES..... 41

PRE-OPERATION CHECKS..... 41
STARTING 41
DRIVING..... 41
 SLOWING AND STOPPING 42
 INCLINES OR SLIPPERY SURFACES 42

STOP THE MACHINE 42
TRANSPORTING THE MACHINE 42
 USING A TRAILER OR TRANSPORT VEHICLE 42

OPTIONS 43

CHEMICAL METERING 43
AUTO-FILL 44
OPERATOR SEAT SENSOR (CE) 44
SPRAY AND VACUUM WAND 45
SUSPENSION SEAT 47
SIDE SCRUB BRUSH 48
SEAT BELTS 48
LIGHTS..... 48

PREVENTATIVE MAINTENANCE..... 50

ELECTRICAL SYSTEM 53
 Battery Cleaning..... 53
 Circuit Breaker 54
LUBRICATION POINTS 55
 Steering Fork Bearings 55
 Rear Wheel Bearings..... 55
 Squeegee Caster Bearings 55

Scrub Head Lift Arm Bearings	55	Replacing Side Squeegee Blades	70
LATCHES & HINGES	56	SIDE SCRUB BRUSH SQUEEGEE (OPTION)	71
STATIC STRAP	56	Replacing Side Scrub Brush Squeegee Blade	71
HYDRAULIC SYSTEM	56	SKIRTS AND SEALS	72
Hydraulic Fluid Reservoir	56	Scrub Deck Front Skirt	72
Changing the Hydraulic Fluid	57	Cover Seals	72
SCRUBBING COMPONENTS	58	BRAKES	73
Scrub Brushes	58	Service Brakes	73
Replace or Rotate the Cylindrical Scrub Brushes	59	Parking Brake	73
Checking the Scrub Brush Pattern	61	Adjusting the Brake System	73
Adjusting the Scrub Brush Pattern (Taper)	62	TIRES	74
Adjusting the Scrub Brush Pattern (Equal width)	63	Changing Solid Tires	74
SIDE SCRUB BRUSH (OPTION)	64	Front Tires	74
Replacing the Side Scrub Brush	64	Rear Tires	74
SQUEEGEES	65	Seat Mount Adjustment	75
Lowering Squeegee for Adjustment	65	SOLUTION DELIVERY BAR & FILTER SYSTEM	75
Checking the Rear Squeegee Blade Flare	65	Solution Delivery Bar	75
Adjusting the Rear Squeegee Blade Flare	66	Solution Filter	76
Leveling the Rear Squeegee	67	TROUBLESHOOTING	77
Turning or Replacing the Rear Squeegee Blades	68		
SIDE SQUEEGEES	70		

FEATURES

AIR-MOVING SYSTEM

- Internal sound insulation on vacuum impeller

ERGONOMICS SYSTEM

- Roomy, open operator compartment for extra comfort
- Toe operated parking brake
- Adjustable, high-back seat
- Unparalleled maintenance accessibility, hinged sides and covers require no tools.

CHASSIS SYSTEM

- Massive One-Piece, unitized 7ga, 0.188 in (0,48 cm) thick steel frame
- Soft-ride tires

ENVIRONMENTAL FRIENDLY FEATURES

SAFER WORK ENVIRONMENT

Orange machines are highly visible to others in the workplace, simple controls reduce operator error. Machine is equipped with a horn and an effective braking system. Some Safety Options available are: Overhead Guard, Backup Alarm, Safety Lights, and Fire Extinguisher.

SAFETY INFORMATION

IMPORTANT SAFETY INSTRUCTIONS

Operators must read and understand this manual before operating or maintaining this machine.

Do not operate this machine in flammable or explosive areas.

This machine is designed solely for removing dirt, dust and debris in an outdoor or indoor environment. PowerBoss does not recommend using this machine in any other capacity.

The following information indicate a potential hazard to the operator and equipment. Read this manual carefully and be aware when these conditions can exist. Take necessary steps to locate all safety devices on the machine and train the personnel operating the machine. Report any machine

damage or faulty operation immediately. Do not use machine if it is not in proper operating condition.

FOR SAFETY DURING OPERATION

Keep hands and feet clear of moving parts while machine is in operation.

Make sure all safety devices are in place and operate properly. All covers, doors and latches must be in place, closed and fastened before use.

During operation, attention should be paid to other persons in the work area and especially if small children are present.

Components can cause an explosion when operated near explosive materials or vapor. Do not operate this machine near flammable materials such as solvents, thinners, fuels, grain dust, etc.

Store or park this machine on a level surface only. To prevent unauthorized use, machine should be stored or parked with

the parking brake set and the key removed.

This machine is designed for level operation only. Do not operate on ramps or inclines greater than 14 degrees (24.9% grade).

This machine is not suitable for picking up hazardous dusts.

Use caution when moving this machine into areas that are below freezing temperatures.

SAFETY WHEN SERVICING OR MAINTAINING THE MACHINE

Stop on level surface, set parking brake and turn off machine.

Disconnect the power to the machine when servicing.

Avoid moving parts. Do not wear loose jackets, shirts, or sleeves when working on machine.

Avoid contact with battery acid. Battery acid can cause burns. When working on or around batteries, wear protective clothing and safety glasses. Remove metal jewelry. Do not lay tools or metal objects on top of battery.

Authorized personnel must perform repairs and maintenance. Use PowerBoss supplied replacement parts.

SAFETY SYMBOLS

Five symbols are used throughout this manual to emphasize various levels of safety information. These symbols and the meaning of each are listed below.

 **DANGER**

To warn of immediate hazards which will result in severe personal injury or death

 **WARNING**

To warn of hazards or unsafe practices which could result in severe personal injury or death.

 **CAUTION**

To warn of hazards or unsafe practices which could result in minor personal injury.

ATTENTION!

To warn of practices which could result in extensive equipment damage.

NOTE: To direct your attention to important equipment information or special instructions for preventing damage to equipment

Symbols at the top of the list are the strongest warnings. However, all symbols represent important information which should be observed to protect you and others from harm and injury, and to prevent damage to the equipment.

SAFETY DECALS

Decals directly attached to various parts of the unit are highly visible safety reminders which should be read and observed. Make sure the decals are replaced if they become illegible or damaged.

Safety decals located in the Operator compartment area:

#3342264:



(Read Manual)

#3301854:



#715967:



Safety decals located on the outside of the machine:

#3342650



#715963



(Pinch Point)

Safety Decal on inside of Recovery Tank Cover:

#715965



Safety decals on inside of Main Brush Side Doors:

#715968

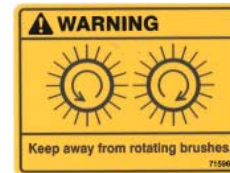

Safety decal located in the compartment area:

#3301730:



BASIC POWERBOSS® SAFETY

PowerBoss® scrubbers should never be operated unless:

1. The operator is trained and authorized to operate the equipment and,
2. The equipment is functioning correctly.
Malfunctioning equipment should be removed from service.

DANGER

Keep cigarettes, matches and all other flame sources away from the machine. Lead acid batteries are dangerous due to the highly explosive hydrogen gas they emit.

WARNING

Before turning on the machine, make sure that:

- * You have read and understood this User Manual
- * You are securely seated in the operator's seat.
- * The parking brake is engaged.

WARNING

During operation:

- * Keep your hands and body clear of moving parts, especially when the bumper is partially or fully raised.
- * Make sure others in the area stay clear of the machine, equipment, and moving parts.

 **WARNING**

When leaving the scrubber unattended:

- * Place the controls in the OFF position.
- * **SET THE PARKING BRAKE.**
- * Remove the key.

 **WARNING**

During cleaning and maintenance:

- * Always turn off the machine and set the parking brake before servicing.
- * Never use detergents or cleansers that are flammable or combustible.
- * Never inflate a pneumatic tire without using a safety
- * Never test for hydraulic hose leaks using your hand or any other part of your body. High pressure leaks can be very dangerous and should only be checked using a piece of paper.

 **WARNING**

Replace any defective safety components before operating the scrubber.

 **CAUTION**

Do not drive with the bumper in the raised position. Driving with the bumper raised increases the risk of damaging the bumper and other hazards.

 **CAUTION**

Travel slowly on grades.

 **CAUTION**

Place a block or chock behind the wheels when parking on inclines.

 **CAUTION**

Use special care when traveling on wet surfaces.

 **CAUTION**

Observe all proper procedures for operation and maintenance of the unit, as outlined in this manual.

 **CAUTION**

Remain alert at all times to people and equipment in and around your area of operation.

ATTENTION!

Never push or tow this machine faster than 1 mph (1,6 km/h).

MACHINE OPERATION

OPERATING CONTROLS AND INDICATORS

The right dark gray portion of the instrument panel contains the machine function switches and indicators.

The left light gray portion of the instrument panel contains the scrubbing function switches and indicators.

KEY SWITCH

The key switch is located to the right of the steering column and is used to start and stop the machine.

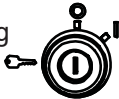

LIGHT SWITCH

The light switch is located on the left side of the operator compartment. It operates the head lights and tail lights.



HORN BUTTON

The horn is activated by pressing the horn button which is located to the right of the steering column below the throttle switch.



CIRCUIT BREAKER

The Circuit Breakers are located on the lower left wall of the operator compartment, and electrical box. To reset the Circuit Breaker press the breaker button in until breaker stays in position.



HOUR METER

The hour meter, located on the left side of the operator compartment. This meter records the number of hours the machine has been operated. The hour meter provides a helpful guide for performing routine maintenance tasks, located in the Maintenance Section of this manual.

INDICATOR LIGHTS

RECOVERY TANK FULL INDICATOR

When the recovery tank is nearly full the red “full recovery tank” indicator lamp on the instrument panel will begin to blink on and off. When the lamp stops blinking and remains illuminated the tank is full. A few seconds later the scrubbing and squeegee systems



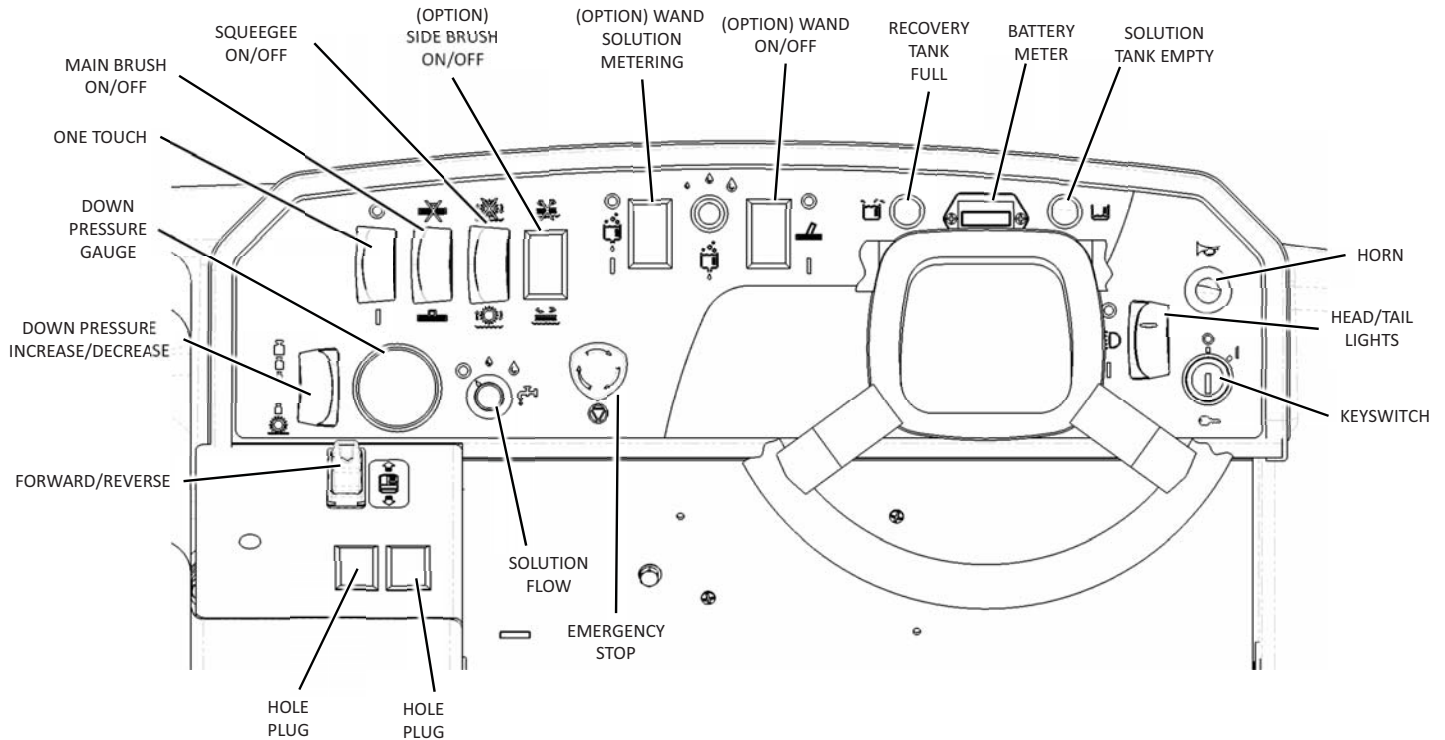

automatically shut off and all components are raised to their stored positions. The vacuum fan will continue to operate for a short time.

SOLUTION TANK EMPTY INDICATOR

When the solution tank is nearly empty a red indicator lamp on the instrument panel will blink on and off. When the lamp stops blinking and remains illuminated there is solution remaining for approximately 10 minutes of scrubbing time.



BATTERY DISCHARGE INDICATOR

The battery discharge indicator displays the charge level of the batteries while the machine is operating. When the batteries are fully charged, all five bars are lit. Recharge the batteries when there is only one bar shown in the display. Do not allow the batteries to discharge below 20% (last bar).

DIRECTIONAL CONTROL SWITCH

The directional control switch is used to control the direction of the machine in either forward or reverse.

- To propel the machine forward, push the switch forward.
- To propel the machine backward, push the switch down.

BRAKE / PARKING BRAKE

The mechanical drum brakes on the two rear wheels are operated by pressing on the brake pedal. To engage the parking brake push on the brake pedal then depress the upper brake lock to set the parking brake. To release the parking brake depress the brake pedal

SEAT ADJUSTMENT

The drivers seat is adjustable to provide the most comfortable position for the operator. The adjustment lever is at the bottom front of the seat. While sitting in the seat, push the lever to the right and pull forward or push back on the seat. Release the lever when the seat is in the proper location.

CONTROL PEDAL

The control pedal determines the speed of the machine in forward or reverse. Apply pressure to the pedal to increase speed. Decrease pressure to the pedal to slow down. Release pressure from the pedal to stop the machine.

INSTRUMENT PANEL CONTROL SWITCHES

The main scrubbing controls are located on the main instrument panel for easy access and operator identification. See additional information on the Instrument Panel Control Switches.

GREEN “ONE TOUCH” SWITCH

A green “One-Touch” switch operates the entire scrubbing function.

SQUEEGEE SWITCH

This switch operates the Squeegee and Vac Fan.

SCRUB BRUSH SWITCH

This switch operates the Scrub Brushes.

SIDE SCRUB BRUSH SWITCH - OPTION

This switch operates the Side Scrub Brush.

SOLUTION FLOW SWITCH

This switch controls the Solution Flow and has three settings: Off, Normal, and High.

CHEMICAL METERING SWITCH - OPTION

This switch operates the Chemical Metering.

CHEMICAL METERING FLOW SWITCH - OPTION

This switch controls the Chemical Metering Flow and has three settings: Low, Medium, and High.

VAC AND SPRAY WAND SWITCH - OPTION

This switch operates the Vac and Spray Wand.

SCRUBBING CONTROL DETAILS/FUNCTIONS

Below are the details and functions of the main scrubbing control switch indicators. These controls/switches are located to the left of the steering column for easy access and operator identification.

GREEN “ONE-TOUCH” SWITCH

The green “One-Touch” switch operates the entire scrubbing function. When the One-Touch control switch is turned on the following takes place:

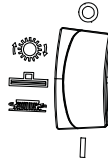

1. When the vehicle is in motion, the scrub head lowers to the floor, the main brushes turn on, and the solution control valve is activated. The solution flow will default to the last flow rate chosen but can be varied as required.
2. The main brush down pressure will default to the daily scrub position.
3. The squeegee lowers to the floor and the vacuum fan turns on.
4. If installed the optional side scrub brush will extend, lower, and turn on, and the side brush solution flow will turn on.
5. If installed the chemical metering system will turn on.

SQUEEGEE SWITCH

A separate Squeegee switch is provided. It can be used to prevent the squeegee functions from operating when the “One-Touch” switch is activated (Allowing for scrubbing only or double scrubbing operation).



SCRUB BRUSH SWITCH

A separate Scrub Brush switch is provided. It can be used to prevent the main scrub brush functions from operating when the “One-Touch” switch is activated (Allowing for squeegee only operation).



SIDE SCRUB BRUSH SWITCH - OPTION

A separate Side Scrub Brush Switch is provided as an option. It can be used to prevent the side brush from operating when the “One-Touch” switch is activated.

When the vehicle motion is stopped the brushes (including the side brush, if installed) and solution flow will automatically shut off. When the vehicle begins to move the scrub brushes and the solution automatically resume operation.



When the scrubber is driven in reverse the squeegee automatically raises from the floor.

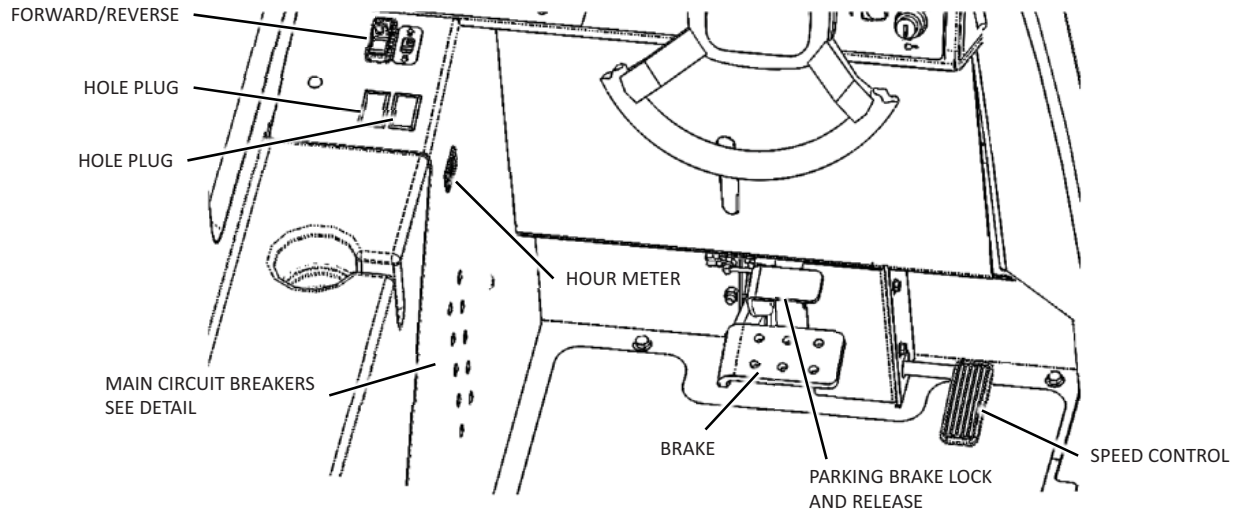

MAIN BRUSH SCRUB PRESSURE SWITCH

The Main Brush Scrub Pressure is selected using a rotary control knob which provides three pressure settings: Light = 200 lb (90,7 kg); Medium = 300 lb (136,1 kg); and Heavy = 400 lb (181,4 kg). Upon start-up the system responds to the last pressure setting used. The scrubbing pressure can be changed while the scrubber is in operation.



SOLUTION CONTROL KNOB

The solution flow is selected using a three position rotary knob which provides: Off, Low, and High solution flow.



The **Low flow setting** is for normal scrubbing, smooth floors, and light dirt. The flow rate is .88 gal/hr (3,33 L/hr), providing 2.0 hours of scrub time.

The **High flow setting** is for rough floors and heavy or compacted dirt. The high flow rate is 1.50 gal/hr (5,67 L/hr), providing 1.2 hours of scrub time.

Note: The solution flow starts and stops automatically when the solution flow switch is set in the low or high position.

The flow can be manually shut off when sufficient solution is already on the floor.

The side brush solution flow starts and stops automatically. This side brush has only one flow rate. The flow rate is factory set, but can be adjusted by turning the slotted screw on the solution solenoid valve located below the frame just behind the side scrub brush.

BASIC SCRUBBING/FILLING/ EMPTYING INFORMATION

Adjust the machine speed scrub brush pressure and solution flow as required. Use the least amount of brush pressure and solution necessary for the scrubbing application.

When the recovery tank is full the recovery tank indicator light will illuminate and the scrubbing functions will shut off. It is then necessary to drain and clean the recovery tank and refill the solution tank before continuing the scrubbing operation.

CHOOSING THE CORRECT TYPE OF BRUSH (FOR YOUR SCRUBBING APPLICATION)

The main and optional side scrub brushes are available in the following types:

Polypropylene brush (718292)

This is a general-purpose brush good for most cleaning applications.

Nylon brush (718295)

This is a soft brush good for light applications or when scrubbing coated floors.

70/46 grit abrasive brush (718293)

This is a very still scrub brush impregnated with super heavy abrasive grit designed to remove heavy build up like compacted grease and oil from heavy traffic areas.

50/80 grit abrasive brush (718294)

This is a nylon brush impregnated with heavy abrasive grit for removing heavy stains and compacted dirt. This brush is good for heavy buildup grease or tire marks.

180 grit abrasive brush (719533)

This is a nylon brush impregnated with mild abrasive grit for removing heavy stains and compacted dirt.

Soft Polypropylene (719534)

This is a very soft bristle brush designed to clean high shine coated floors like urethane. This brush avoids scratching and removing the shine from the coating.

Note: Reference Nautilus E Part Catalog for reordering main and side scrub brushes.

FILLING THE SOLUTION TANK

Open the top cover of the solution tank. Begin filling the solution tank with clean water not to exceed 130°F (55.4°C). When the tank is approximately half full add the appropriate amount of detergent (Do not add detergent in solution tank if you are using the optional chemical metering system for applying detergent). Continue to fill the solution tank with water. The tank is full when the water level reaches the bottom of the metal level indicator (located inside the solution tank).

If the machine is equipped with an optional chemical metering system do not add detergent in the solution tank. Instead, place a container of cleaning solution into the chemical metering box and install the pump suction hose.

Note: Use only recommended cleaning detergents. Machine damage due to improper detergent usage will void the machine warranty.

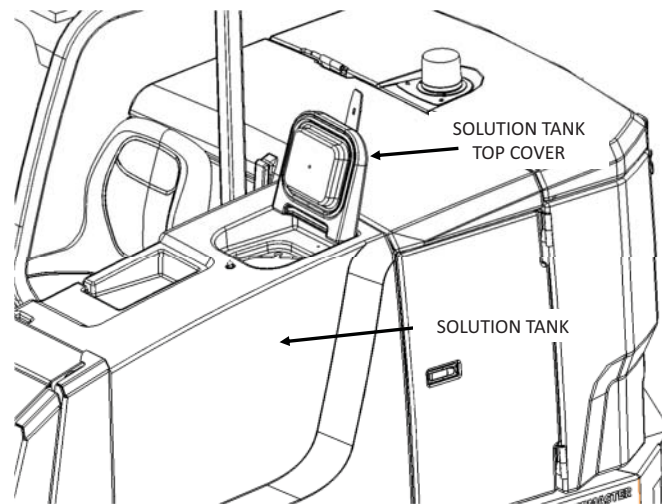

FILLING THE SOLUTION TANK USING THE AUTO-FILL OPTION:

1. Park the machine on a level surface and set the parking brake.
2. Turn the ignition key to the “on” position, do not start the machine.
3. A. Open the side door.
B. Using the quick connector adapter on the end of a water supply hose connect the supply hose to the auto-fill connector.
C. Turn on the water supply. The water will automatically shut off when the proper level is achieved.
D. When the solution tank is full, turn off the water supply.
E. Disconnect the garden hose and close the side door.
4. Turn the ignition key in the “off” position.

 **WARNING**

**Flammable materials can cause an explosion or fire.
Do not use or fill flammable materials in the tank(s).**

NORMAL SCRUBBING

This machine is equipped with one button scrubbing. It is not necessary to press all of the scrub function switches each time you begin scrubbing.



1. Start the machine.
2. Ensure that the squeegee and brush switches (to the right of the green one-touch switch) are in the “on” position. Set the brush pressure switch to the lowest setting required for the scrubbing application. Set the solution control knob to the low flow position. (See Fig. 1)
3. Press the bottom of the green one-touch button to begin scrubbing.

The squeegee will lower, the vacuum fan will start. When the vehicle is driven forward or backward the scrub brushes will lower and start and the solution flow will turn on.

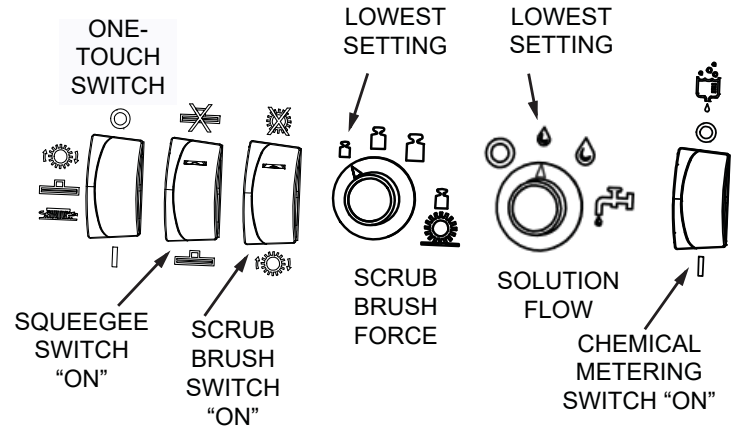

Fig. 1: Control Settings, before “One-Touch” selection

If equipped with the optional side scrub brush: The side scrub brush will extend, lower, and turn on and the solution flow to the side scrub brush will turn on.

Note: when a new container of detergent has been installed a short amount of time is required for the detergent to mix with the water and reach the floor.

4. Drive the machine forward and scrub as required.
5. Adjust the solution flow as necessary.

The low setting is used for normal scrubbing, smooth floors, and light dirt.

The high setting is for rough floors and heavy or compacted grime.

6. Adjust the scrub brush pressure as required.

There are three brush pressures available.

For normal scrubbing use the lowest brush pressure.

Use the medium or high brush pressure for heavier grime as required.

Note: Higher brush pressures will result in higher brush wear.

DOUBLE SCRUBBING

Double scrubbing is an effective way to remove heavy grime accumulation. This is accomplished by making two passes over the area to be cleaned, the first pass with the squeegee raised.

Note: When double scrubbing it is necessary to manually lock the side squeegee blades (and if equipped, the side brush squeegee blade) in the raised position.

1. Manually lock both side squeegee blades in the raised position. Open the scrub brush door. Lift the side squeegee assembly and rotate the lock arms counter-clockwise until they latch and lock the squeegee blade in the raised position. See Fig. 1.
2. If the machine is equipped with the optional side scrub brush, raise the side brush squeegee blade by removing the squeegee retaining strap, relocating the squeegee blade using the lowest positioning slots (highest squeegee position), then replacing the squeegee retaining strap. See Fig. 2.
3. Start the machine.

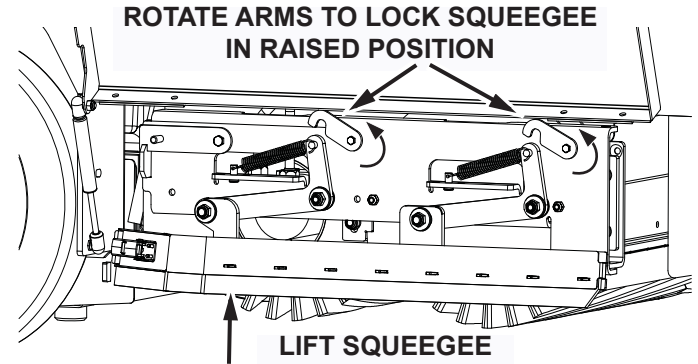

Fig. 1: Shows squeegee assembly retaining arms

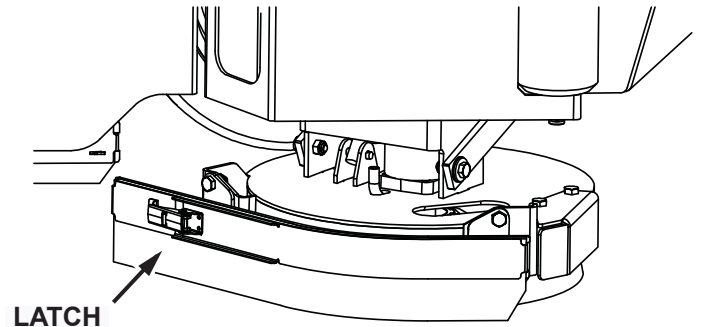

Fig. 2: Optional side scrub brush with squeegee

4. To begin double scrubbing first set the squeegee switch in the “off” position (an illuminated red light on each switch indicates that that function is turned off). This will turn off the vacuum fan and prevent the squeegee from lowering.
5. Press the bottom of the green one-touch button to begin scrubbing.
6. When double scrubbing use the maximum solution flow setting and a high brush pressure.
7. Make a pass over the area to be scrubbed. This will dispense solution over the area allowing the detergent to soak on the floor. Let the solution remain on the floor for 5 - 10 minutes, then make a second pass with the squeegee lowered (squeegee switch in the “on” position).

Use caution when double scrubbing in areas where cleaning solution may run under storage racks or damage product.

Note: When finished double scrubbing, unlock the side squeegee blades and reposition the side brush squeegee blade to its original height.

STOP SCRUBBING

1. Press the top of the green one touch button to stop scrubbing. The scrub brushes will shut off and raise, and the solution flow will shut off. After a few seconds the squeegee will raise and a few seconds later the vacuum fan will shut off.
2. Continue driving the machine forward until the squeegee raises.
3. When finished set the controls back to the normal scrubbing position.

WATER PICK UP MODE (SQUEEGEE ONLY)

For water pick up or cleaning spills the machine can be operated with the squeegee and vacuum system only.

1. Start the machine.
2. To begin operating with only the squeegee and vacuum system, insure that the squeegee switch is in the “on” position and set the scrub brush switch(s) to the “off” position (an illuminated red light on each switch indicates that that function is turned off). (See Fig. 1).
3. Press the bottom of the green one-touch button to begin water pick up or cleaning spills.
4. The squeegee will lower and the vacuum fan will turn on.
5. Drive over the spill areas.

 WARNING
Flammable materials can cause an explosion or fire. Do not use or fill flammable materials in the tank(s).

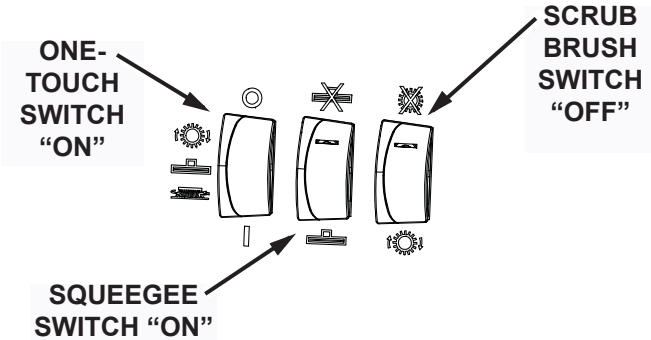

Fig. 1: Control Settings for Water Pick-up Mode

STOP WATER PICK UP

1. Press the top of the green one touch button to stop squeegee operation. After a few seconds the squeegee will raise and the vacuum fan will shut off.
2. IWhen finished set the controls back to the normal scrubbing position.

DRAINING/CLEANING THE RECOVERY TANK

Note: The recovery tank must be emptied and cleaned daily.

When the recovery tank is full or you are finished scrubbing the recovery tank must be drained and cleaned.

1. Drive the machine to an appropriate dump site. Shut off the machine, and set the parking brake.
2. Open the demister. (See Fig. 1)
3. Remove the plug from the end of the recovery hose.
4. Place the end of the recovery tank drain hose on the floor near a floor drain. (See Fig. 1)
5. When the tank is fully drained rinse out the tank with clean water.

Note: Do not use steam to clean the tank as this will damage the tank.

6. Rinse the float sensor, inside the Recovery Tank.
7. When finished cleaning and draining the tank, twist the plug back into the end of the recovery hose.
8. Reinstall the drain hose onto the back of the recovery tank.
9. Close the recovery tank top covers.
10. Rinse off the exterior of the tanks as necessary.

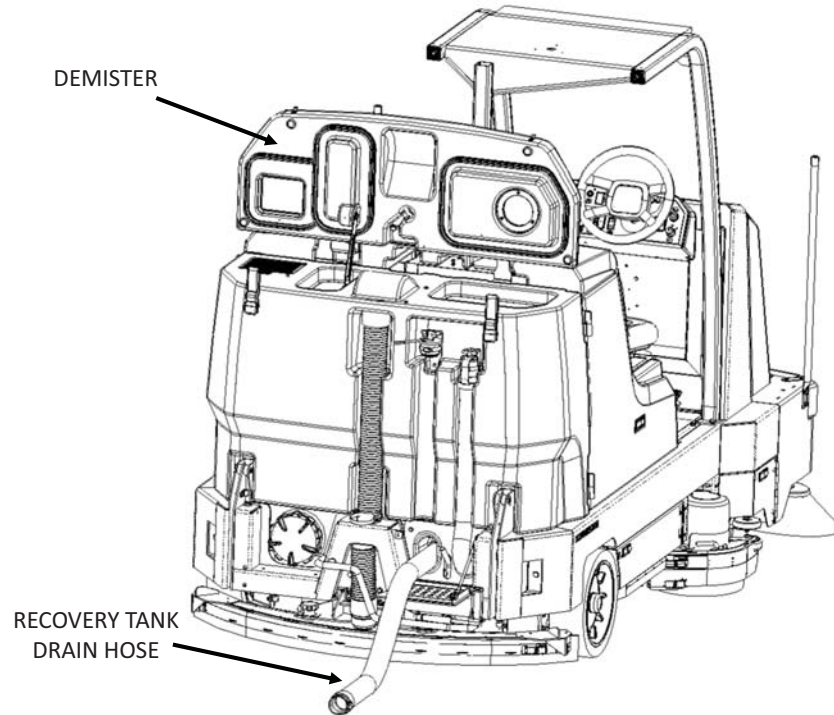

Fig. 1: Draining the Recovery Tank

RAISING THE BUMPER

Note: Raising the bumper is necessary to more easily access the squeegee.

1. Shut off the machine, and set the parking brake.
2. Pull the rear step down into position.
3. Release the rear bumper latch located under the right side of the rear frame while lifting up on the bumper lever arm. (See Fig. 1)
4. Swing the orange bumper lever arm out from under the rear bumper. (See Fig. 1)
5. Raise the bumper up until the safety arm locks into place.

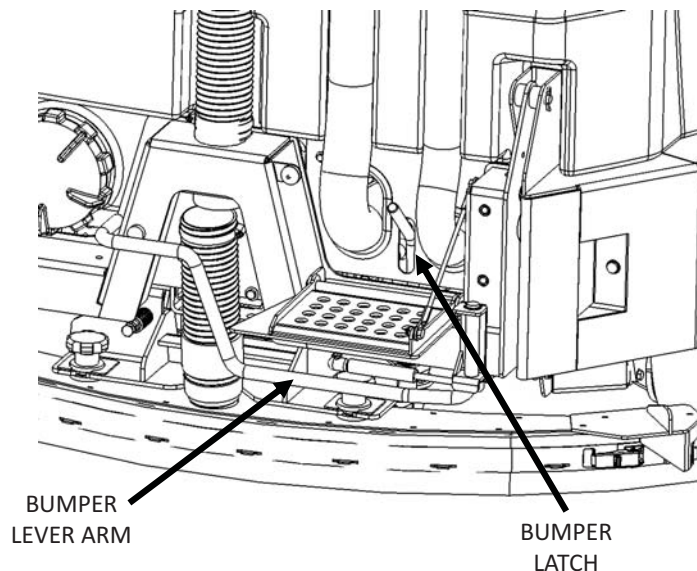
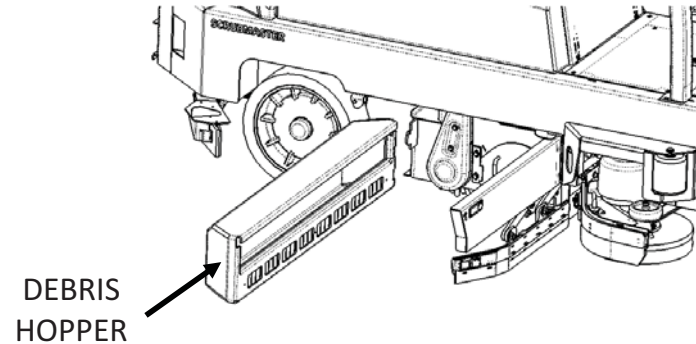

Fig. 1

EMPTYING/CLEANING THE DEBRIS HOPPER

1. Drive the machine to an appropriate dump site.
2. Shut off the machine, and set the parking brake.
3. Open the side door.
4. Slide the debris hopper out from behind the scrubdeck.
5. Empty the debris into an appropriate container.
6. Rinse the hopper clean.
7. Reinstall hopper.
8. Close the side door.



DRAINING THE SOLUTION TANK

1. Drive the machine to an appropriate dump site. Shut off the machine and set the parking brake.
2. Open the solution tank top cover.
3. Grab the end of the solution tank drain hose and lower slowly to the floor near floor drain. (See Fig. 1)
4. Loosen and remove the cap. (See Fig. 1)

Note: Depending on the level of liquid in the solution tank the liquid may exit under pressure.

5. After tank has fully drained reinstall the cap.
6. Reinstall the drain hose onto the back of the recovery tank.
7. Close the solution tank top cover.

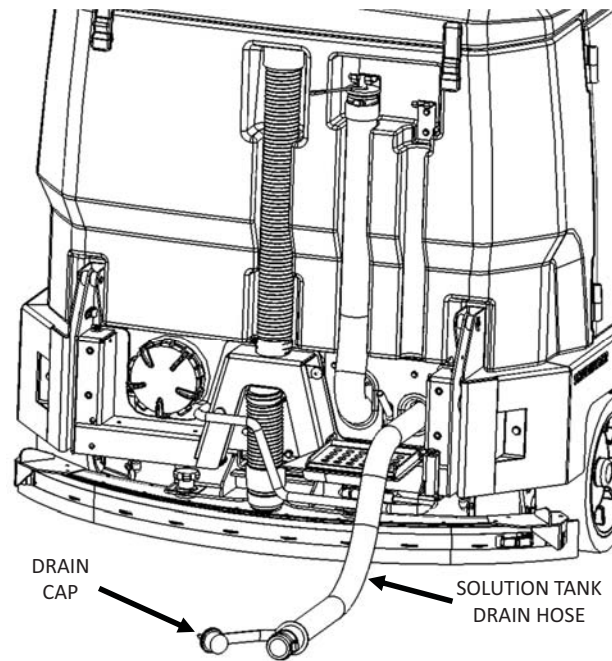

Fig. 1: Draining the Solution Tank

OPERATING PROCEDURES

PRE-OPERATION CHECKS

Prior to starting the machine, check the following:

1. Confirm the battery is charged.
2. Hydraulic fluid level is within the operating range -- indicated fluid level within the sight gauge.
3. Brakes, steering, and directional controls.
4. Signs of fluid leaks on and under the machine.
5. Condition of scrubbing brushes. Remove any strings and debris wrapped around them.

Fluid levels should be within the correct amounts to operate the machine.

Brakes, steering and directional controls should be functioning properly.

Hoses, lines and tanks should be free of damage and leaks.

STARTING

WARNING

Before starting the machine, sit in the operator's seat and make sure the parking brake is engaged.

1. Engage the parking brake.
2. Turn the ignition key to the start position (clockwise).

DRIVING

The direction control pedal moves the machine forward and backward. To move the machine forward or backward, first release the parking brake.

- To move Forward: Push the directional switch forward. Use the control pedal to control the speed.
- To move Backwards: Push the directional switch down. Use the control pedal to control the speed.

SLOWING AND STOPPING

Allow the directional control pedal to move into neutral. Step on the brake pedal.

INCLINES OR SLIPPERY SURFACES

Always travel slowly when operating on inclines or slippery surfaces.

WARNING

Do not travel across or turn on inclines, to maintain stability of the machine.

Always travel straight up or down on inclines.

STOP THE MACHINE

1. Stop scrubbing and drive the machine forward until the rear squeegee raises.
2. Stop the vehicle using the foot brake.
3. Turn off the ignition key switch to the off position.
4. Remove the key.
5. Set the parking brake.

TRANSPORTING THE MACHINE

USING A TRAILER OR TRANSPORT VEHICLE

1. Position the machine on the transport vehicle or trailer and apply the parking brake.
2. Tie the machine down using the tie down bars on both sides of the front corners and behind both rear wheels.

Note: Attach the tie downs to the tie down bars only.

CAUTION

The tow control valve must be turned 90 degrees from the operating position.

Not turning the tow control valve will cause damage to the pump.

ATTENTION!

Do not tow or push the machine a distance of more than 0.5 mi (0,8 km) or faster than 1 mph (1,6 km/hr). Exceeding these restrictions may cause damage. If towing will exceed the above restrictions, the rear wheel must be raised or supported by a dolly.

OPTIONS

CHEMICAL METERING

The chemical metering option is used to meter the optimum amount of detergent onto the floor while scrubbing.

1. Place a full container of detergent (appropriate for the application) into the detergent container rack located on the top of the solution tank. (See Fig. 1)

Note: Use only recommended cleaning detergents. Machine damage due to improper detergent usage will void the machine warranty.

2. Remove the detergent container cap and replace it with the suction hose cap.
3. Set the chemical metering flow rate. (See Fig. 2)
There are chemical flow rates available. For normal scrubbing use the lowest chemical flow rate. For heavier scrubbing use the medium or high chemical flow rate.
4. Turn on the chemical metering switch. (See Fig. 2)
5. When scrubbing, the correct amount of detergent will automatically be added to the solution delivery system.

Note: During the first use after a new container of detergent is installed it may take some additional time for the detergent to reach the floor.

AUTO-FILL

The auto-fill option allows for unattended filling of the solution tank.

The system automatically shuts off the flow of water to the solution tank when the tank is full. See the section on “filling the solution tank” for more details on this option.

OPERATOR SEAT SENSOR (CE)

The Operator Seat Sensor safety option senses when the operator of the vehicle is sitting in the driver seat. This sensor will automatically turn off the running machine, if the operator leaves the seat for longer than 3 seconds. If the parking brake is engaged it will bypass the seat contact switch so that the machine will continue to run so the mechanic can work on it.

This safety option is standard on Nautilus E CE machines and available for other Nautilus E machines.

SPRAY AND VACUUM WAND

The spray wand option is used to clean areas that are otherwise inaccessible.

1. Park the machine close to the area to be cleaned.
2. Lower the squeegee and shut off the machine.
3. Set the parking brake.
4. Remove the hose from the top of the rear squeegee.
5. Remove the spray wand tubes from the retainer clips and assemble the wand.
6. Remove the vacuum hose from the hose rack and attach the small end of the hose to the upper end of the wand and the large end of the hose to the machine squeegee hose.
7. Attach the wand solution hose to the quick disconnect fitting on the upper end of the wand and to the quick disconnect fitting located on the rear bumper of the machine between the tank drain hoses. (See Fig. 1)
8. Start the machine.
9. Lower the squeegee to turn on the vacuum system.
10. Turn the Vac & Spray Wand switch located on the instrument panel to the “on” position. (See Fig. 2)

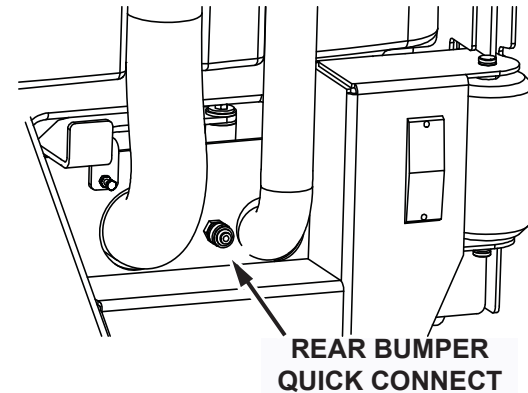

Fig. 1: Spray Wand Quick Disconnect

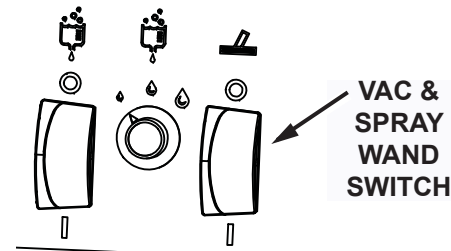

Fig. 2: Vacuum and Spray Wand Switch

11. Apply solution to the area to be cleaned by activating the solution valve lever on the upper end of the wand.
12. Use the brush bar on the lower end of the wand to scrub the area to be cleaned.
13. Vacuum the floor using the squeegee on the lower end of the wand.

 **WARNING**

**Flammable materials can cause an explosion or fire.
Do not vacuum/pick up flammable materials.**

When wand cleaning is complete:

14. Turn off the Vac & Spray Wand switch.
15. Shut off the machine.
16. Remove the wand vacuum hose from the wand and the machine squeegee.
17. Re-connect the machine squeegee hose onto the machine squeegee.
18. Put the wand and wand vacuum hose in the wand clips and hose rack.

SUSPENSION SEAT

The suspension seat comes equipped with:

1. Hand lever for seat adjustment.

Adjusts the seat lengthwise. Pull lever to release. Let the lever catch after adjustment.



1

2. Rotary knob for lumbar adjustment.

Turn knob to the left for more support. Turn the knob to the right for less support.



2

3. Rotary knob for backrest adjustment.

Turn knob to the left to incline the seat backward. Turn the knob to the right to bring the seat back up.



3

4. Rotary knob for cushion adjustment.

Turn knob to the right for firmer cushion support. Turn knob to the left for softer cushion support.



4

5. Armrest adjustment screw.

Adjusts the inclination of the armrest.



5

SIDE SCRUB BRUSH

Turn on the side brush using the side brush switch on the console. Turn off the side brush using the same switch.

The side brush cannot operate independently from the main sweep brushes. The main brushes also come on when the side brush switch is pushed.

SEAT BELTS

Seat belts are offered as an option on both the standard seat, and the suspension seat.

LIGHTS

Safety lights are offered in blue, amber, or red. The lights can be mounted on the solution tank, or the Overhead Guard. The lights can flash, rotate, or strobe.

The lights will come on automatically when the machine is turned on.

PREVENTATIVE MAINTENANCE

Introduction

Regular maintenance on your sweeper results in better cleaning, faster cleaning and a prolonged service life for the equipment and components. This section contains the following information to help you give your sweeper the maintenance attention it requires:

- A Scheduled Maintenance Chart
- Preventative Maintenance Instructions for Required Scheduled Maintenance Tasks

Because it is extremely important to your safety, you will see the following WARNING repeated throughout this section:

WARNING

Never attempt to perform any service on the equipment or components until:

- 1) The Vehicle is Parked on a LEVEL GROUND.**
- 2) The machine is OFF.**
- 3) The Parking Brake is LOCKED.**
- 4) The Wheels are CHOCKED.**

FREQUENCY (IN HOURS)	SERVICE (BY MAINTENANCE AREA)
50	Scrub Head Skirts (disk)- Check for damage and wear
	Sweeping Skirts - Check for damage and wear
	Sweeping Side Brush(es) - Check brush pattern
	<i>Solution Supply Filter - Check screen and clean</i>
	Live Wand Vacuum Seals (Option) - Check for damage and wear
100	Battery Watering System (Option) - Check hoses and connections for damage and wear
200	Brakes - Check adjustments
	Battery Terminals and Cables - Check and clean
	Cylindrical Brush Drive Belts - Check for damage and wear
	Sweeping Brush Drive Belts - Check for damage and wear
	Drive Wheel pivot - lubricate
	Steering Chain - lubricate
	Steering Gear Chain -lubricate
500	Scrub Vacuum Fan Motor(s) - Check motor brushes
	Tires - Check for damage and wear

FREQUENCY (IN HOURS)	SERVICE (BY MAINTENANCE AREA)
800	Hydraulic Hoses - Check for damage and wear
1000	Sweeping Side Brush Motors - Check motor brushes (check every 100 hours after initial 1000 hour check)
	High Pressure Washer Motor - Check motor brushes (check every 100 hours after initial 1000 hour check)
2400	Hydraulic Reservoir - Change hydraulic fluid

ELECTRICAL SYSTEM

Battery Cleaning

1. Combine baking soda and water in a strong solution.
2. Brush the solution over the battery top, including terminals and cable clamps. Make sure the solution does not enter the battery.
3. Using a wire brush, clean the terminal posts and cable clamps.
4. Apply a thin coating of petroleum jelly to the terminals and cable clamps.

Battery Replacement

 **CAUTION**

Remove the negative battery cable before you remove the positive battery cable. This is done to prevent accidental electrical shorting which can result in personal injury.

1. Disconnect the negative (-) cable and then the positive (+) cable.
2. Remove the battery.
3. Install the new battery.
4. Connect the positive (+) battery cable first, then the negative (-) cable.

Circuit Breaker

If the circuit breaker trips, it can be reset by pressing the reset button in the center of the breaker. (The circuit breakers are located below the left panel of the steering wheel). Press the reset button to reset the circuit breaker.

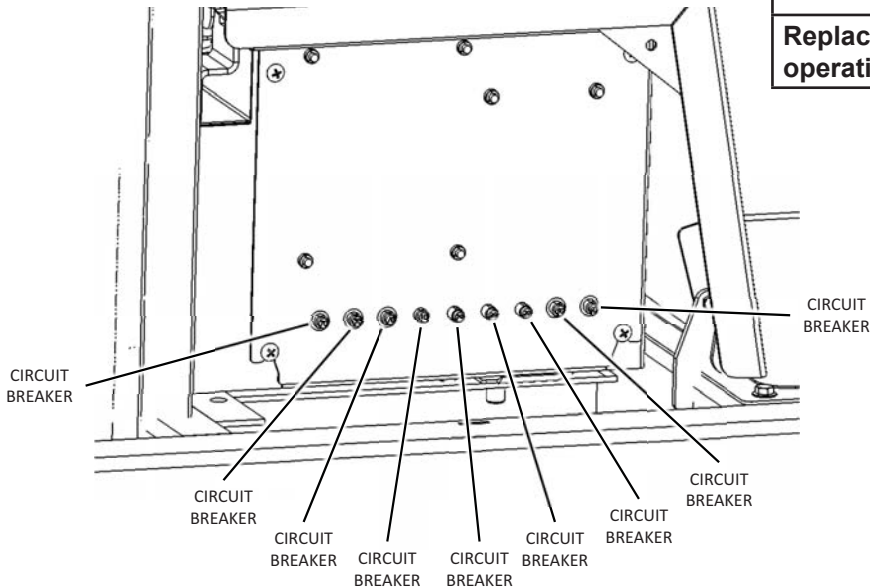

⚠ WARNING

Never attempt to perform any service on the equipment or components until the parking brake is **LOCKED**, and the wheels are **CHOCKED**.

⚠ WARNING

Replace any defective safety components before operation the sweeper.

LUBRICATION POINTS

Steering Fork Bearings

The steering fork bearings are located above the front wheel.

Rear Wheel Bearings

Repack the rear wheel bearings every 400 hours of operation using Lubriplate EMB grease and replace damaged seals.

Squeegee Caster Bearings

Lubricate the squeegee caster bearings every 100 hours using Lubriplate EMB grease.

Scrub Head Lift Arm Bearings

Lubricate the scrub head lift arm bearings every 500 hours with light oil.

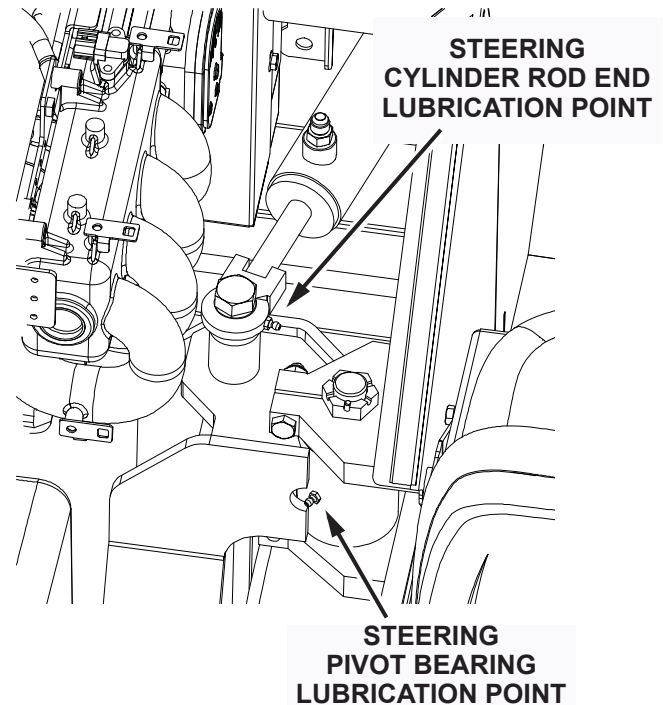

Fig. 1: Lubrication Points

LATCHES & HINGES

Lubricate the cover hinges every 200 hours of operation with light machine oil. Lubricate the following:

- Front cover, hinges and latches
- Side doors, hinges and latches
- Top cover, hinges and latches
- Scrub head doors

The scrub head lift arm bearings are located on both sides of the machine just above the scrub head. These bearings can be best accessed when the scrub head is in the lowered position.

Lubricate the steering fork bearings every 100 hours using Lubriplate EMB grease.

STATIC STRAP

A static strap prevents the buildup of static electricity in the machine. The static strap is attached to the back of the frame behind the left rear tire. Replace the static strap if it is damaged or no longer touches the floor.

HYDRAULIC SYSTEM

Hydraulic Fluid Reservoir

The hydraulic fluid reservoir is located in the front of the machine on the left side. (See Fig. 1)

Note: Only fill tank when arms are in downposition.

The reservoir has a sight gauge to quickly view if there is a sufficient amount hydraulic oil in the reservoir tank to run the machine. Check daily and add hydraulic oil as needed.

 **CAUTION**

**DO NOT OVERFILL HYDRAULIC RESEVOIR TANK!
DO NOT USE TRANSMISSION FLUID!**

 **CAUTION**

**Minuteman International, Inc. recommends using:
Dextron Automatic Transmission Fluid**

Changing the Hydraulic Fluid

1. Turn off the machine and engage the parking brake.
2. Place a drain pan under the reservoir tank.
3. Remove the drain plug, unscrew with 5/16 in (8 mm) hex head wrench, located on the bottom of the reservoir and allow the fluid to drain.
4. Discard the fluid in an approved manner, then replace and retighten the drain plug.
5. Remove the fill cap located on top of the reservoir and fill the reservoir with the recommended hydraulic fluid: (Mobil DTE 10 Excel 32 Hydraulic Oil or equivalent).

Note: A minimum of 7 gal - 8 gal (26.5 L - 30.3 L) of hydraulic oil is needed to fill the empty reservoir tank to the correct amount. The maximum volume capacity of the hydraulic reservoir tank is 9.9 gal (37.5 L). Do not fill to this maximum capacity!

6. Visually see if the hydraulic oil level is at or above the sight gauge. Confirm the hydraulic oil level is within the high and low markers on the dip stick. Add or remove hydraulic fluid as needed. (Reference approximate fill line)

7. Verify the fill cap is hand tight to prevent leakage.
8. Start the machine, shut it off, then check for leakage.

SCRUBBING COMPONENTS

Scrub Brushes

This machine is equipped with two cylindrical scrub brushes. These brushes scrub the floor and also sweep debris into the debris hopper. These brushes should be checked daily for wear and damage as well as entangled string, plastic, or wire.

It is important for optimum debris pick up that the brushes be installed with the V-shaped bristle patterns pointing toward each other when viewed from above as shown.

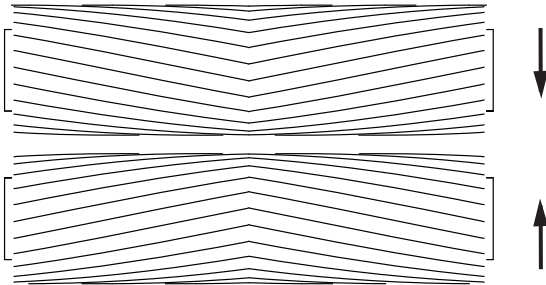

Fig. 1: Scrub Brush pattern

When installing the brushes insert the drive hub end of the brush into the scrub head. This automatically insures that the brush V-shaped pattern is positioned correctly.

To increase brush life these scrub brushes can be rotated front-to-rear.

The brush wear indicator should be used to determine when the brushes should be replaced.

Note: Always replace the cylindrical scrub brushes in sets to prevent poor scrubbing efficiency.



Replace or Rotate the Cylindrical Scrub Brushes

1. Set the machine parking brake. (See Fig. 2)
2. Open the scrub brush side door.
3. Turn the solution flow switch to off position. (See Fig. 3)

For Safety: Before leaving machine, turn off the machine, set the parking brake, and remove the key.

Note: In order to service both cylindrical scrub brushes the following steps must be performed on both sides of the scrubber.

4. Release the retaining latch at the rear of the side squeegee mount and swing the side squeegee mount open. (See Fig. 4)
5. Using the handles pull the brush idler plate away and free from the scrub deck. (See Fig. 5)
6. Pull the brush out from the scrub deck. (See Fig. 5)

Note: The scrub deck may have to be raised slightly to install new brushes.

PARKING BRAKE

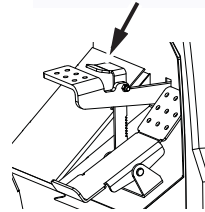

Fig. 2: Set the Praking Brake



Fig. 3: Solution Flow Switch off

RETAINING LATCH

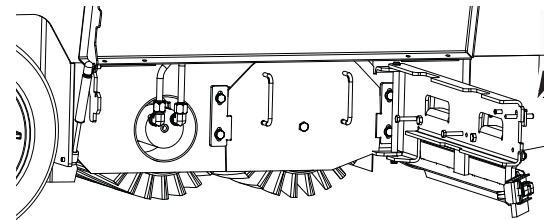

Fig. 4

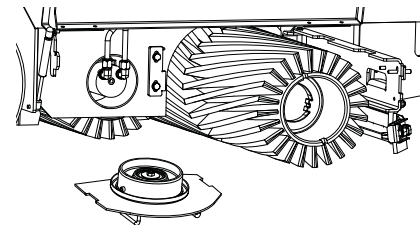

Fig. 5

7. Slide the new or rotated scrub brush into the scrub deck. Insure that the V-shaped bristle patterns on the brushes are pointing toward each other as viewed from above. (See Fig. 6)
8. Push the scrub brush onto the drive hub while rotating the brush counter-clockwise. Insure that the brush is fully seated onto the drive hub.
9. Install the idler hub into the end of the scrub brush while guiding the idler plate onto the two brush adjustment plates.
10. Close and latch the side squeegee mount. The side squeegee mount holds the brush idler plate in place.
11. Lower the scrub brush side door.
12. Repeat this procedure with the second cylindrical scrub brush on the other side of the scrubber.
13. Raise the scrub head.
14. Check and if necessary adjust the brush pattern as described in the section on **Checking the Scrub Brush Pattern**, page 69.

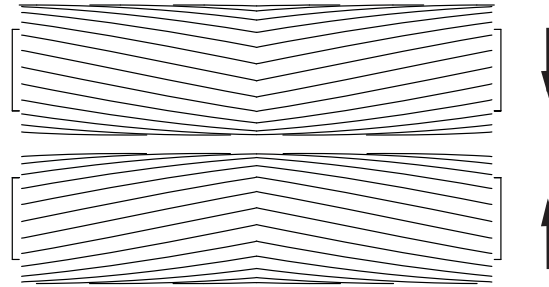

Fig. 6: Scrub Brush pattern

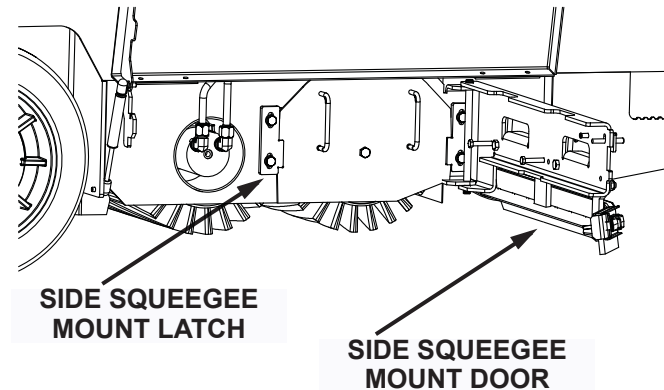

Fig. 7: Scrub Brush pattern

Checking the Scrub Brush Pattern

For the best results perform the scrub brush pattern tests on a smooth even floor.

Note: Chalk or chalk powder applied to the floor will help to show the brush pattern. If chalk is not available allow the brushes to turn on the floor for 1 or 2 minutes. A polished brush pattern will be visible on the floor.

1. Raise the scrub deck.
2. Position the scrub deck over the chalked area.
3. Set the parking brake.

For Safety: Before leaving machine, turn off the machine, set the parking brake, and remove the key.

4. Lower the scrub head for 10-15 seconds. Do not allow the machine to move forward or backward.
5. Raise the scrub deck.
6. Release the parking brake and drive the machine away from the chalked area.

7. Check the width and shape of the brush patterns on the floor. If the long edges of the two brush patterns are parallel then a brush pattern adjustment is not required.

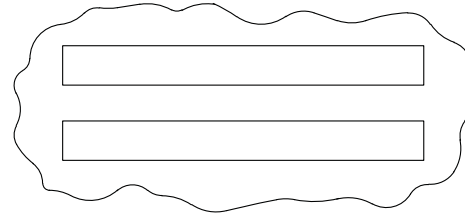

Fig. 1: Brush Pattern Correct

If only one of the scrub brush patterns is tapered then only that brush pattern must be adjusted. If both of the brush patterns are tapered then both brush patterns must be adjusted.

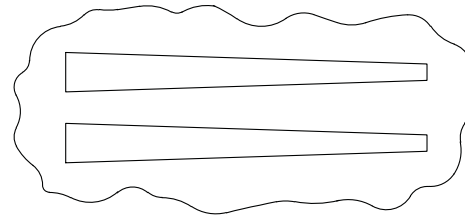

Fig. 2: Brush Pattern Incorrect

Adjusting the Scrub Brush Pattern (Taper)

The front scrub brush pattern adjustment is located behind the right side scrub brush door.

The rear scrub brush pattern adjustment is located behind the left side scrub brush door.

1. Raise the scrub brush side door.
2. Release the retaining latch at the rear of the side squeegee mount and swing the side squeegee mount open.
3. Loosen the four pattern adjustment nuts located on either side of the scrub brush idler plate.
4. Raise or lower the scrub brush idler plate as necessary to correct the tapered brush pattern. Raising the idler plate will decrease the brush pattern width on that side of the scrub deck.

Note: Lowering the idler plate will increase the brush pattern width on that side of the scrub deck.

5. Tighten the four pattern adjustment nuts.
6. Close and latch the side squeegee mount. The side squeegee mount holds the brush idler plate in place.
7. Check the scrub brush pattern again and readjust if necessary.

The brush patterns should also be the same width. If one is wider than the other then the scrub brush pattern width must be adjusted.

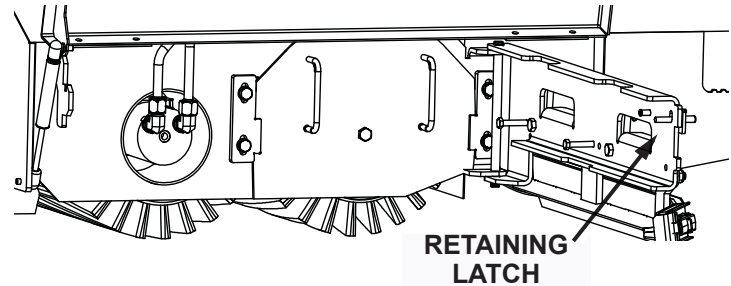

Fig. 1: Retaining Latch location

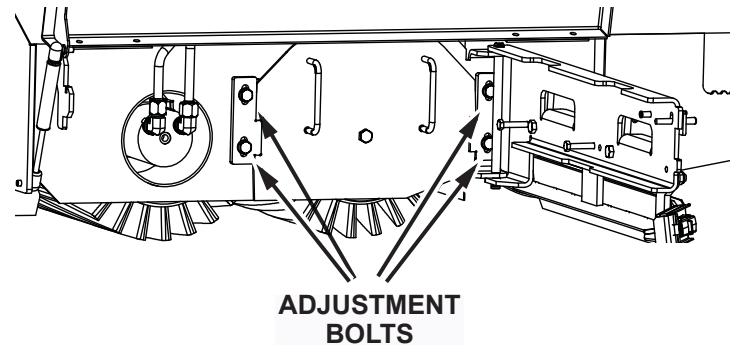

Fig. 2: Adjustment Bolts, location

Adjusting the Scrub Brush Pattern (Equal width)

The width of the two scrub brush patterns should be equal. If they are not equal the level of the scrub deck must be adjusted front-to-back. (See Fig. 3)

1. Open the two side doors and raise the seat mount.
2. Lengthen or shorten the leveling rods located on each side of the machine above the scrub deck. Lengthening the rods will increase the front scrub brush pattern width. (See Fig. 4)
3. Adjust the leveling rods in equal amounts.
4. Check the scrub brush pattern again and readjust if necessary.

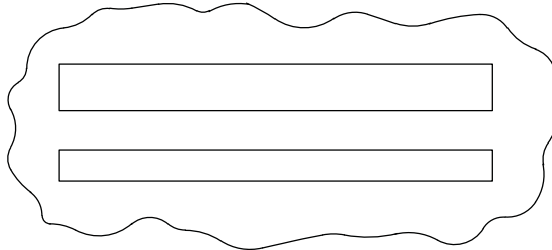

Fig. 3: Brush Pattern (width not equal)

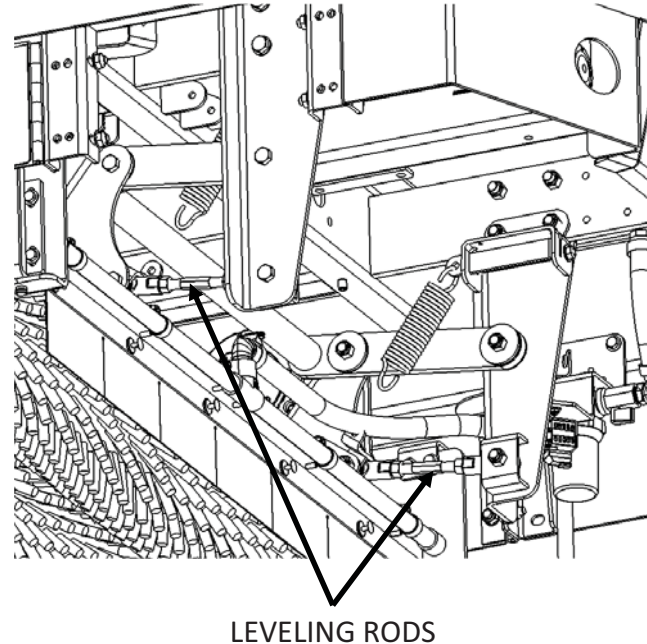

Fig. 4: Leveling Rod location

SIDE SCRUB BRUSH (OPTION)

Replacing the Side Scrub Brush

1. Raise the side scrub brush.
2. Turn off the machine.
3. Set the parking brake.

For Safety: Before leaving machine, turn off the machine, set the parking brake, and remove the key.

4. Rotate the brush until the brush release tabs are accessible through the opening in the brush guard.
5. Press the release tabs together. The brush will fall off of the brush drive hub.
6. Lift a new brush onto the brush drive hub to lock it into place.
7. Check to be sure that the brush is securely retained.

Note: Check the side brush daily for wear. The side scrub brush should be replaced when it is no longer cleaning effectively, or the bristle length has worn to 2.5 inches (5,08 cm) from the block.

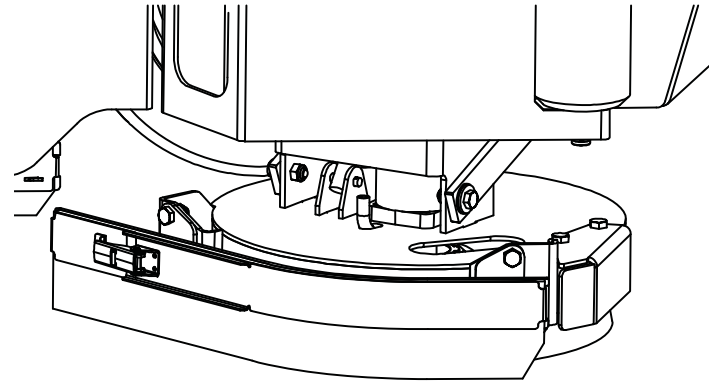

Fig. 1: Replacing the Side Scrub Brush

SQUEEGEES

The right and left side squeegees control water during turns and channel water toward the center of the machine and into the path of the rear squeegee.

The rear squeegee channels water to the center of the squeegee where it is removed by the vacuum fan.

The optional side scrub brush squeegee channels water to the inside of the right side squeegee.

Check the squeegee blades daily for wear or damage.

Replace or rotate the squeegee blades if the edges are torn or worn half-way through the thickness of the blade.

The rear squeegee blades must be adjusted to be level and for correct deflection.

Lowering Squeegee for Adjustment

To lower the squeegee for adjustment. Follow the steps below:

1. With machine running; Turn “on” green one touch and Squeegee switch. Squeegee will lower to the ground.
2. Turn off the key switch.
3. Squeegee will remain on the ground. Repeat steps 1-3, if necessary.

4. The squeegee can be adjusted.

Checking the Rear Squeegee Blade Flare

Squeegee flare is the amount of curl in the squeegee blade as it drags on the floor while the machine is moving forward. Correct squeegee blade flare is necessary for optimum water pick up. The correct flare adjustment is achieved when the squeegee wipes the floor dry with the least amount of deflection. It is important that this check be performed on an even, level surface.

1. Lower the squeegee.
2. Drive the machine forward approximately 2 ft (0,6 m).
3. Set the parking brake.
4. Examine the curl in the squeegee rubber to see that the flare is correct and that it is uniform around the entire back edge of the squeegee blade:

If the flair is uniform but the amount of flare is incorrect proceed to the section on **Adjusting the Rear Squeegee Blade Flare**.

If the flare is not uniform proceed to the section on **Leveling the Rear Squeegee**.

Adjusting the Rear Squeegee Blade Flare

Be sure that the squeegee assembly is adjusted to level before performing the flare adjustment. It is important that this adjustment be performed on an even, level surface.

Note: Raising the squeegee casters increases the squeegee flare, lowering the casters reduces the squeegee flare.

1. Lower the squeegee.
2. Turn off the key switch Set the parking brake.
3. Lift the squeegee assembly up by hand and allow it to rest back down on the floor. The squeegee blade should be standing straight up on the floor with no flair.
4. Loosen the locking knobs on the squeegee casters.
5. Adjust the casters until they clear the floor by .25 in (0,63 cm). Use a .25 in (0,63 cm) thick spacer for this procedure.
6. Check the squeegee flare (See **Checking the Rear Squeegee Blade Flare**).
7. Test the squeegee for water pick up.
8. Make fine adjustments to the caster height for optimum water pick up on the floor surface to be cleaned.

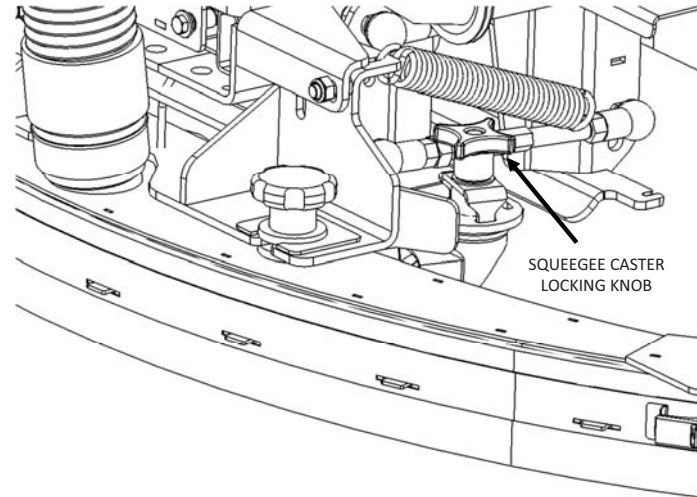

Fig. 1: Adjusting the Rear Squeegee Blade Flair

Leveling the Rear Squeegee

Leveling the squeegee assembly provides a uniform flare of the squeegee blade. It is important that this adjustment be performed on an even, level surface.

1. Lower the squeegee.
2. Drive the machine forward approximately 2 ft (0,6 m).
3. Set the parking brake.
4. Examine the curl in the squeegee rubber around the entire back edge of the squeegee blade.

If the flare is not even across the rear squeegee blade proceed with the following:

5. Locate the pitch rod adjustment nuts on the lift plate.

Note: Raising the rear bumper and then lowering the squeegee will provide greater access to the adjusting nuts.

6. To lower the front of the squeegee turn the two adjustment nuts on each adjustment rod rearward (away from the front of the machine).

To lower the rear of the squeegee turn the two adjustment nuts on each adjustment rod forward (toward the front of the machine).

7. Lock the adjustment nuts.

8. If necessary proceed to **Adjusting the Rear Squeegee Blade Flare.**

9. Test the squeegee for water pick up.

10. Re-adjust to level the squeegee if necessary.

Turning or Replacing the Rear Squeegee Blades

Check the squeegee blades daily for wear or damage.

After the squeegee edge wears half-way through the thickness of the squeegee blade the squeegee blade can be turned over so that a new edge will be against the cleaning surface.

After the second edge wears the squeegee blade can be turned end-to-end to use the third edge, and finally turned over once again to use the fourth edge.

Replace any damaged squeegee blade.

Note: The rear squeegee blade can be accessed with the rear bumper raised or closed. With the rear bumper raised the outer squeegee can be turned or replaced without removing the squeegee tool from the machine. Servicing the inner squeegee is best done with the squeegee tool removed from the machine.

1. Ensure that the rear squeegee is raised up off of the floor.
2. Shut off the machine and set the parking brake.

For Safety: Before leaving machine, turn off the machine, set the parking brake, and remove the key.

3. Raise the rear bumper.
4. Loosen the two squeegee retaining knobs. (See Fig. 1)
5. Pull the lower end of the squeegee hose from the squeegee tool. (See Fig. 1)
6. Lift the squeegee tool off of the squeegee frame

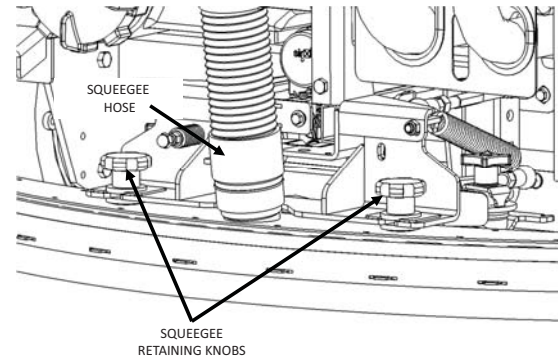

Fig. 1: Turning/Replacing the Rear Squeegee Blades

7. Remove the squeegee retainer bands. (See Fig. 2)

8. Replace or turn the squeegee blades by placing the blade onto the pins of the squeegee frame.

9. Replace the squeegee retainer straps and close the latch.

Note: When reinstalling the squeegee tool insure that the washers below the squeegee retaining knobs are positioned between the knobs and the squeegee tool mount.

10. Lower the rear bumper.

11. Adjust the rear squeegee as shown in Adjusting the Rear Squeegee Blade Flare.

SIDE SQUEEGEES

The right and left side squeegees control water during turns and channel water toward the center of the machine and into the path of the rear squeegee.

Replace the side squeegees if they become worn, damaged, or lose their shape.

Replacing Side Squeegee Blades

1. Raise the scrub deck.
2. Turn the key off and set the parking brake.

For Safety: Before leaving machine, turn off the machine, set the parking brake, and remove the key.

3. Open the side squeegee door.
4. Open the latch on the side squeegee retaining strap and remove the retaining strap. (See Fig. 1)

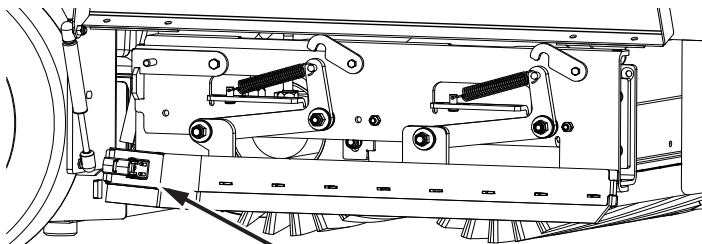

Fig. 1: Side Latch

SIDE LATCH

5. Replace the side squeegee blade by placing the blade onto the pins of the side squeegee frame.

Note: Position the beveled edge of the side squeegee blade down and toward the front the machine.

6. Replace the side squeegee retainer strap by first hooking the forward end around the notch at the front edge of the side squeegee frame. (See Fig. 2)

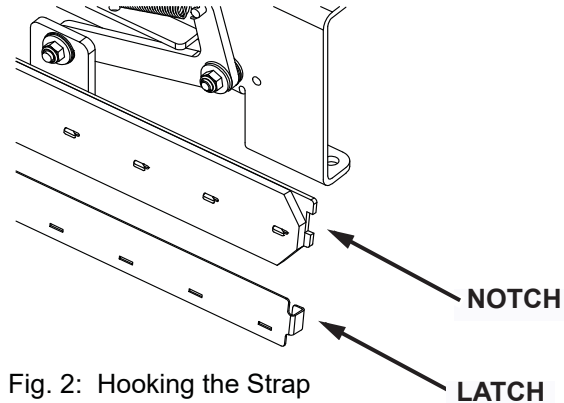

Fig. 2: Hooking the Strap

LATCH

7. Close the latch on the side squeegee retaining strap and close the side squeegee door.
8. Repeat the procedure for the side squeegee on the other side of the machine.

SIDE SCRUB BRUSH SQUEEGEE (OPTION)

The side scrub brush squeegee channels water to the inside of the right side squeegee and into the path of the rear squeegee.

Replace the side scrub brush squeegee if it becomes worn, damaged, or loses its shape.

Replacing Side Scrub Brush Squeegee Blade

1. Remove squeegee guard by unlatching from side brush.
2. Open the latch on the squeegee retaining strap and remove the retaining strap. (See Fig. 3)
3. Replace the squeegee blade by placing the appropriate set of holes on the squeegee blade onto the pins of the side squeegee frame.
When the side scrub brush is new: Use the upper set of holes.
When the brush is moderately worn: Use the center set of holes.
When the brush is very worn: Use the lower set of holes.

Note: Position the beveled edge of the squeegee blade down and toward the front the machine.

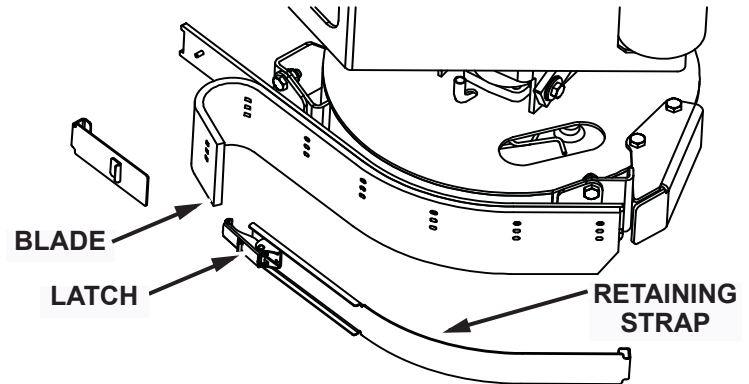

Fig. 3: Retaining Strap & Blade

4. Replace the squeegee retainer strap by first hooking the separate straps around the notches at the front and rear edge of the squeegee frame.
5. Close the latch on the side squeegee retaining strap.

SKIRTS AND SEALS

Scrub Deck Front Skirt

The Front Skirt is mounted to the front of the scrub deck.
(See Fig. 1)

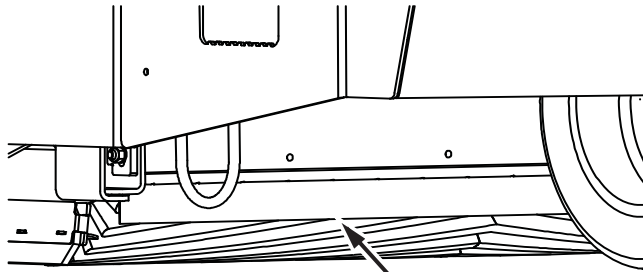

Fig. 1: Scrub Deck Front Skirt

**CHECK SKIRT
FOR WEAR**

Check this skirt for wear or damage every 100 hours of operation.

Cover Seals

The Cover Seals are attached to each of the solution and recovery tank covers. (See Fig. 4)

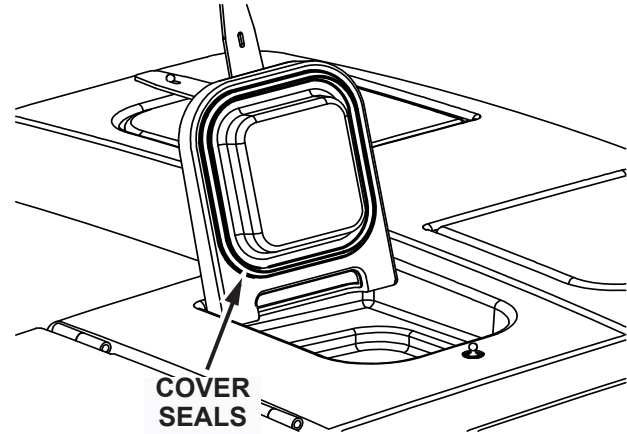

Fig. 4: Cover Seals

Check these seals for wear or damage every 100 hours of operation.

BRAKES

Service Brakes

The service brakes are operated by a foot pedal and connecting cables. (See Fig. 1)

Check the service brake adjustment every 200 hours of operation.

Parking Brake

The parking brake is operated by a locking foot pedal that activates the service brakes. (See Fig. 1)

Check the service brake adjustment every 200 hours of operation.

Adjusting the Brake System

Both the service and parking brake are adjusted during the following cable length adjustment.

The brake cable adjustment is located under the operator behind the scrub deck. (See Fig. 1)

1. Loosen the locking nut on the adjustment hex bar.
2. Adjust the length of the cable by turning the adjustment hex bar.

Note: The cable should be adjusted so that there is little play in the brake pedal but not so tight to cause the brakes to drag when the brake pedal is released.

3. Test the brakes and re-adjust if necessary.
4. Tighten the locking nut.

TIRES

The front and rear tires are solid press-on tires.

Check the tires for damage every 100 hours of operation.

Changing Solid Tires

Note: The procedures that follow apply to SOLID TIRES ONLY!

Front Tires

1. ??????
2. ??????..
3. ??????..
4. ??????..
5. T?????..

Rear Tires

1. Remove the tire from the vehicle by removing the center axle nut.
2. Pull the rear tire straight off of the axle.

3. Remove the inner and outer bearings. Note which is the inner bearing and which is the outer bearing so that they are reinstalled in the same location.
4. Press the tire from the rim.
5. Press the new tire onto the rim.
6. Clean the inner and outer bearing races and bores.
7. Clean the bearings. Inspect the bearings and races for wear, replace if necessary.
8. Grease the bearings with LUBRIPLATE EMB Grease or equivalent.
9. Install the bearings in the wheel. Insure that the bearing seals are seated correctly and being careful not to get any grease on the brake surface or brake pads.
10. Reinstall the tire on the machine by holding the wheel parallel to the side of the vehicle and firmly push it onto the axle.
11. Torque the wheel nut to 60 lb·ft (81 N·m).
12. Align the hole in the axle with the closest slot on the nut and install the cotter pin.
13. Install the hub cap.

Seat Mount Adjustment:

The seat mount is opened by pulling on the latch handle protruding out from the front of the seat mount then lifting the back of the seat mount.

The seat mount will lock in the raised position. To unlock the seat mount lift the seat mount lock arm and lower the seat mount.

The seat mount can be removed by first disconnecting the lock arm from the frame pin and then rotating the two seat mount hinge retaining bars toward the front of the machine. The seat mount can then be lifted off.

To reinstall the seat mount set the seat mount into the hinge receivers, reconnect the lock arm, and lower the seat mount. The seat mount retaining bars will latch automatically.

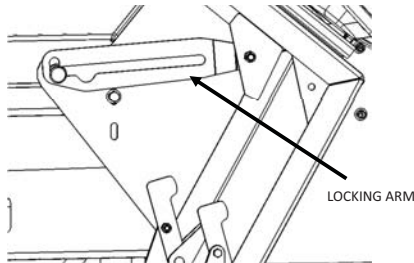

Fig. 2

SOLUTION DELIVERY BAR & FILTER SYSTEM

Solution Delivery Bar

Located under the machine and in front of the main brush housing, visually inspect the Solution Delivery Bar for plugged discharge holes. Clean the discharge holes with a small wire brush or pipe cleaner as needed. Keep the holes free and clear of debris. (See Fig. 1)

Check the Solution Delivery Bar every 200 hours of operation.

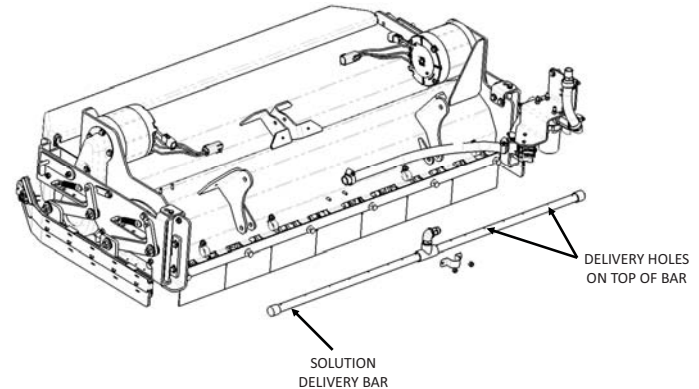

Fig. 1: Solution Delivery Bar shown with holes

Solution Filter

Turn the ke off, and set the parking brake. The solution filter is located on the left side of the machine in front of the scrub deck. Visually inspect the filter element for debris. Clean filter element with fresh water and a small brush. Keep the filter element free of debris. (See Fig. 2)

1. Shut off the valve.
2. Unscrew filter cap counter clockwise to remove the filter cap and filter element from base.
3. Clean filter element with fresh water and a small brush to remove debris.
4. Reassemble filter and screw filter cap back on to base.

Check the water Solution Filter every 50 hours of operation.

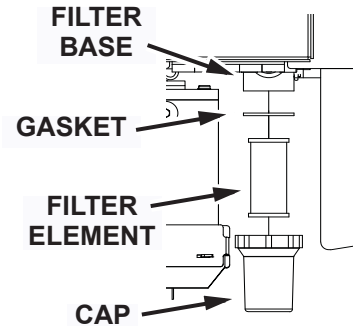

Fig. 2: Water Solution Filter with Exploded view

TROUBLESHOOTING

This section provides information to assist in identifying maintenance trouble and provides possible causes and actions to correct the problem. Many of the solutions require servicing your machine. Service must be preformed by an approved authorized repair station.

TROUBLESHOOTING CHART		
PROBLEM	POSSIBLE CAUSE(S)	SOLUTION(S)
Machine will not start or runs roughly after start.	Battery dead	Recharge or replace battery.
	Circuit Breaker 2 tripped	Reset the circuit breaker
	Keyswitch bad	Replace it
Nautilus E® machine moves slowly or does not move.	Parking brake is on.	Release brake.
	E-stop button depressed	Release it
Brushes do not turn or turn very slowly.	Brush switch not on.	Press to on position.
	Foot pedal not depressed.	Press to forward position.

TROUBLESHOOTING CHART

PROBLEM	POSSIBLE CAUSE(S)	SOLUTION(S)
Poor water pick-up	Worn or torn squeegee blades	Rotate or replace blades
	Squeegee out of adjustment	Adjust so blades touch floor evenly across entire width
	Recovery tank is full.	Empty the tank; if foaming badly, change detergent
	Recovery tank lid gasket leak	Replace gasket lid cover properly
	Debris caught in squeegee	Clean squeegee
	Vacuum hose clogged	Remove debris and flush hose
	Using too much solution	Adjust solution control valves
	Vacuum hose to squeegee or recovery tank disconnected to squeegee or damaged	Reconnect or replace squeegee hose
Inadequate solution flow or no solution being delivered to the floor	Solution tank is empty.	Fill tank
	Solution solenoid valve	Clean or replace valve
	Recovery tank full	Clear lines
	Solution lines, valves, filter or spray jets clogged	Flush lines, and clean solution filter and spray jets

TROUBLESHOOTING CHART		
PROBLEM	POSSIBLE CAUSE(S)	SOLUTION(S)
Scrubber unit not cleaning the floor.	Brushes worn.	Rotate or reeplace brushes
	Need different type of brush or detergent.	Use manufacturer's recommended brushes / detergent
	Debris caught in brush drive mechanism.	Clear obstruction
	Brushes out of adjustment.	Adjust
	Moving machine too fast	Slow down
Scrub head will not lower	Fuse blown	Replace fuse
	Loose scrub head switch wires	Connect wires
	Loose connection of plug at actuator	Connect
	Defective actuator	Replace actuator
	Defective scrub head switch	Replace switch
	Circuit Breaker 3, 10 amp breaker triped	Reset it
Squeegee will not lower.	Loose or defective squeegee switch (on console).	Reconnect wiring or replace switch.
	Loose wire(s) at foot pedal.	Connect.
	Foot pedal switches need adjustment.	Re-adjust cams.

TROUBLESHOOTING CHART		
PROBLEM	POSSIBLE CAUSE(S)	SOLUTION(S)
Squeegee will not raise in reverse or by console switch.	Foot pedal switches need adjustment.	Re-adjust cams.
	Defective solenoid valve.	Replace solenoid valve or coil.
	No power at valve.	Check fuse.

TROUBLESHOOTING DRIVE CONTROLLER (718199)		
PROBLEM	POSSIBLE CAUSE(S)	SOLUTION(S)
Unit will not drive	Over heated-temp sensor open	let cool down
Neither LED illuminated, but controller is operating normally	Controller is not powered on	F-1 (300amp) fuse blown, R-1 relay bad, or not switching, Circuit breaker 2 tripped, E stop pushed in.
	Vehicle has dead battery, or severely damaged battery	Call service
Yellow LED flashing	Check Drive motor connections	Call service
Yellow and red LEDs both on solid	Controller is in flash program mode	Call service
Red LED on solid	Internal hardware fault detected by the supervisor or primary microprocessor	Call service
	Missing or corrupt software (Interrupting a software download may cause corruption of the software)	Cycle KSI to clear. Reload or replace controller if necessary. Call service.

TROUBLESHOOTING DRIVE CONTROLLER (718199)		
PROBLEM	POSSIBLE CAUSE(S)	SOLUTION(S)
Red LED and yellow LED flashing alternately	Controller has detected a fault. (2 digit code flashed by yellow LED identifies the specific fault. One or two flashes by red LED indicate whether first or second code digit will follow.	Call service

TROUBLESHOOTING STEERING CONTROLLER (718203)		
PROBLEM	POSSIBLE CAUSE(S)	SOLUTION(S)
Unit will not steer	Circuit Breaker 9 (30 amp) tripper	Reset the breaker
	Check J1-15 for 36 volts supply voltage Possible broke/pinched wire from key switch	Call service
LED blinks 8 times	Controller detects a failure on the external power fuse/power connections or internal relay damaged	Check Breaker 9, and J1-15 relays, if okay, then call service.
LED blinks 10 times	Battery voltage upper than 45V,.	Check the battery or power connections status. Call service
LED blinks 11 times	Motors ammeter protection	Check motor connections. If good, call service.

TROUBLESHOOTING STEERING CONTROLLER (718203)

PROBLEM	POSSIBLE CAUSE(S)	SOLUTION(S)
LED blinks 12 times	Motor's thermal switch ON	Let cool, and try again. If still not steering, call service.
LED blinks 13 times	Key switch was opened.	Check the key switch connections. If good, call service.

TROUBLESHOOTING BRUSH CONTROLLER (714623)

PROBLEM	POSSIBLE CAUSE(S)	SOLUTION(S)
Brushes not turning	Check circuit breakers 6 and 7	Reset breaker.
Controller Code A5	Thermal protection	Wait few minutes and check the motor current.
Controller Code A9	Under-voltage	Check batteries charge.
Controller Code A11	Overload Protection	Check the motor working current, and parameters "rated current" and "overload time"
Controller Code A12	Disable switch on	Check the input switch. This alarm will reset by power-off.
Any other Controller Codes		Call Service.

PowerBoss[®]

The Power of Clean

**PowerBoss[®] is a Full Line Manufacturer of Sweepers and Scrubbers,
for Industrial Facilities.**

PowerBoss[®], Minuteman International, Inc., 14N845 U.S. Route 20 Pingree Grove, Illinois 60140
Phone: 800-323-9420 www.PowerBoss.com e-mail: tech@powerboss.com
A Member of the Hako Group

Nautilus E Rider Cylindrical Scrubber / Sweeper #988768UM Rev. B 06/20

© 2014-2015 Minuteman International, Inc.